



Application

Due to the choice of materials and its design, PROLAC HCP SP (Self-Priming) is suitable for applications requiring a high level of hygiene, gentle handling of the product and resistance to chemical attack.

The HCP SP pump is particularly suitable for pumping liquids containing air or gas without losing its pumping capacity. It can be used in the food-processing, pharmaceutical and chemical industries. Its main application is the return of the CIP cleaning system.

Operating principle

The PROLAC HCP SP is a self-priming pump that eliminates the need for a vacuum pump or other devices such as foot valves or additional pipes.

The pump needs to be primed with liquid only once before start up. When the pump is turned on, it sucks the air or gas present in the suction pipe, mixing it with the liquid in the pump body. The centrifugal forces push the mixture of liquid and gas towards the separator tank where it loses speed. Because of gravity, the liquid remains at the bottom of the separator tank and is driven back to the pump body through the return pipe, while the air or gas is released through the discharge pipe. In this way, the air or gas is continuously being removed from the suction pipe until the liquid reaches the pump body and the pump begins to operate like a normal centrifugal pump.

It is very important the sucked air is released through the discharge pipe without any back pressure.

It is not advisable to reduce the hydraulic performance of the pump by resizing the impeller or lowering the speed by means of a frequency converter, since it will have negative repercussions on the pump's suction capacity.

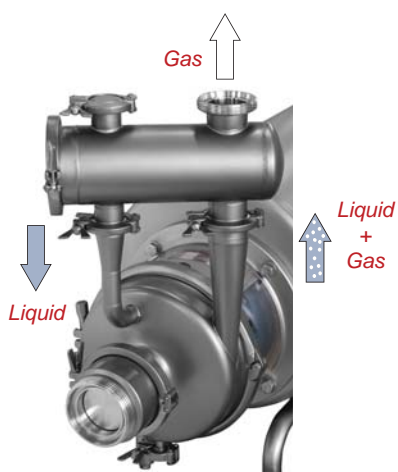

Operating principle

Design and features

The PROLAC HCP SP has the same components as the PROLAC HCP. The key difference between the two pumps is the body. The impeller, seal and all the other parts are the same in both pumps.

The body of the PROLAC HCP SP includes a separator tank and a non-return valve, ensuring high levels of efficiency.

The motor complies with the IEC standards and is protected by a stainless steel shroud and provided with height adjustable stainless steel legs of hygienic design.



I Technical specifications

Materials

Parts in contact with the product	Stainless steel 1.4404 (AISI 316L)
Other steel parts	Stainless steel 1.4301 (AISI 304)
Gaskets in contact with the product	EPDM

Mechanical seal

Rotary part	Silicon carbide (SiC)
Stationary part	Carbon (C)
Gaskets	EPDM

Surface finish

External	Matt
Internal	Bright polish $Ra < 0,8 \mu m$

Connections

DIN 11851 (standard)
 CLAMP OD
 SMS 1145
 (other connections available on request)

Operating limits

Nominal pressure	1600 kPa (16 bar)	232 PSI
Temperature range	-10°C to +120 °C	14 °F to 248 °F
	+140°C (SIP, max. 30 min.)	284 °F
Maximum flow	110 m ³ /h	484 US GPM
Maximum differential head	60 m	197 ft
Maximum speed	3600 rpm	

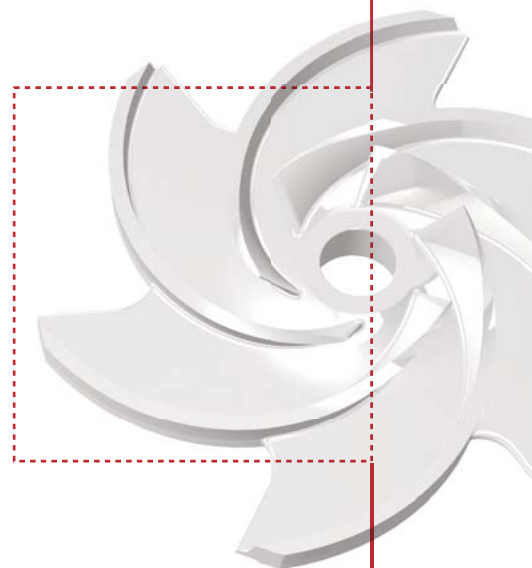

I Motor

Triphasic induction motor with B5 flange and B3 legs, in compliance with the IEC standards, 2 poles = 3000/3600 rpm, IE-2 efficiency class, IP 55 protection and F-class insulation.

3 phases, 50 Hz, 220-240 V Δ / 380-420 V Y, ≤ 4 kW
 3 phases, 50 Hz 380-420 V Δ / 660-690 V Y, ≥ 5,5 kW

I Options

- Different types of connections.
- SiC/SiC mechanical seal.
- Double mechanical seal.
- FPM gaskets.
- Motor with other voltages, frequencies and protection classes.
- Motor for explosive atmospheres or with enhanced safety level.



I Dimensions

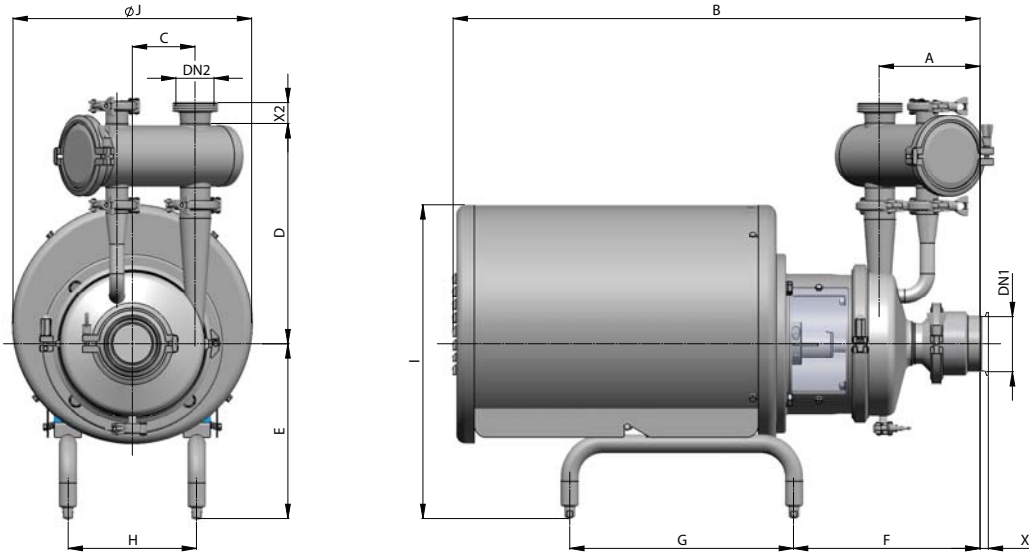

Dimensions X₁, X₂

	DN ₁	DN ₂	DIN 11851		SMS 1145		CLAMP OD	
			X ₁	X ₂	X ₁	X ₂	X ₁	X ₂
50-150	65 (2 ½")	50 (2")	0	35	27	38	28,6	28,5
50-190								
65-215	80 (3")	65 (2 ½")	0	40	27	42	29	28,5

Dimensions

	kW	Motor	DN ₁	DN ₂	A	B	C	D	E	F	G	H	I	ØJ	kg
HCP SP 50-150	1,5	90	65	50	174	658	72	329	227	290	275	132	386	270	40
	2,2	90				658			227	290	275	132	386	270	42
	3	100				736			266	288	325	175	451	330	53
	4	112				736			278	294	325	175	463	330	58
HCP SP 50-190	3	100	65	50	169	730	105	370	266	282	325	175	451	330	58
	4	112				730			278	288	325	175	463	330	63
	5,5	132				862			293	312	375	216	508	380	79
	7,5	132				862			293	312	375	216	508	380	93
HCP SP 65-215	7,5	132	80	65	193	903	120	432	293	353	375	216	508	380	104
	11	160				1133			367	398	475	267	642	465	150
	15	160				1133			367	398	475	267	642	465	164
	18,5	160				1133			367	398	475	267	642	465	182

Dimensions in mm



The information is for guidance only. We reserve the right to modify any material or feature without notice in advance. Photos are not binding. For further information, please, consult our web site. www.inoxpa.com

FT:HCP-SP-1.EN-0913

I Performance charts

